

6BY3-220 / 6BY3-260

Configuration	4-stroke, water-cooled diesel engine		
Maximum output at crankshaft	162 kW@4000 rpm	[220 mhp@4000 rpm]	
	191 kW@4000 rpm	[260 mhp@4000 rpm]	
Displacement	2.993 ltr	[183 cu in]	
Bore x stroke	84 mm x 90 mm	[3.31 in x 3.54 in]	
Cylinders	6 in line		
Combustion system	Direct injection with Bosch Common-rail system		
Aspiration	Turbocharger + charge-air cooler		
Low Idle rpm	650 - 950 rpm	[adjustable]	
Electric system	12V		
Alternator	12V - 150A		
Start-assist	Glow-plug system		
Cooling system	Fresh water cooling by centrifugal fresh water pump		
	Sea water cooling by rubber impeller seawater pump		
Lubrication system	Enclosed, forced lubricating system		
Direction of rotation [crankshaft]	Counter clockwise viewed from flywheel side		
Dry weight without gear	328 kg	[723 lbs]	
Environmental	EU: RCD	BSO II	EMC
	US: EPA Tier3		
	IMO: MARPOL 73/78 Annex VI		
	SOLAS MED 96/98/EC		
Engine mounting	Rubber type flexible mounting		

NOTE:

Fuel condition: Density at 15°C = 0.84 g/cm³

Fuel temperature 40°C at the inlet of the fuel injection pump [ISO 8665: 2006]

Technical data is according to ISO 8665: 2006/3046-1

DIMENSIONS

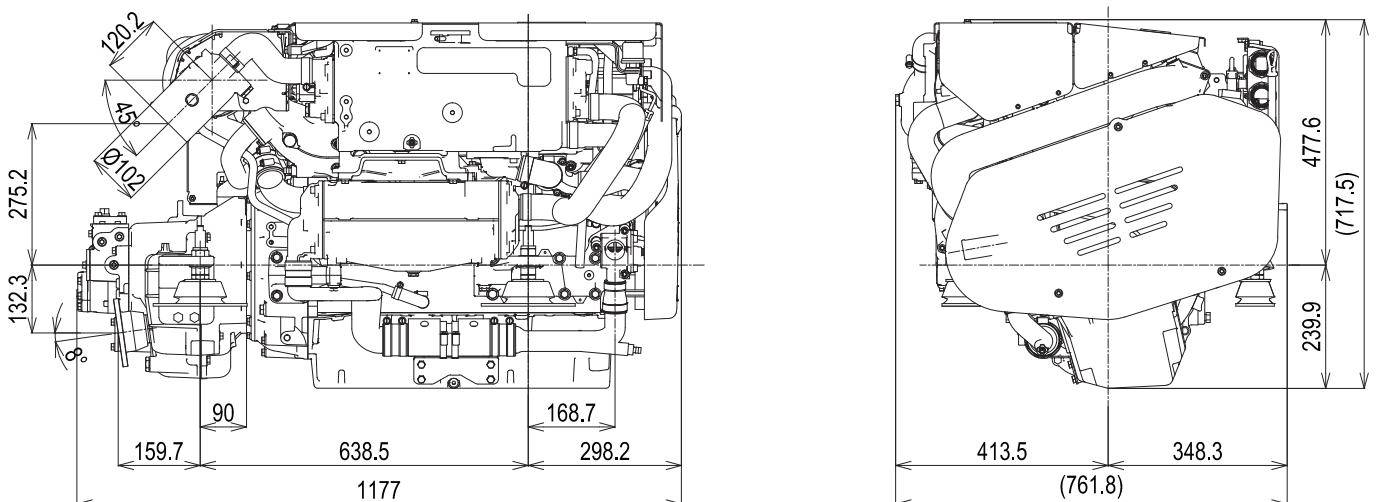

6BY3-260 with KMH51A Marine gear

PERFORMANCE CURVES

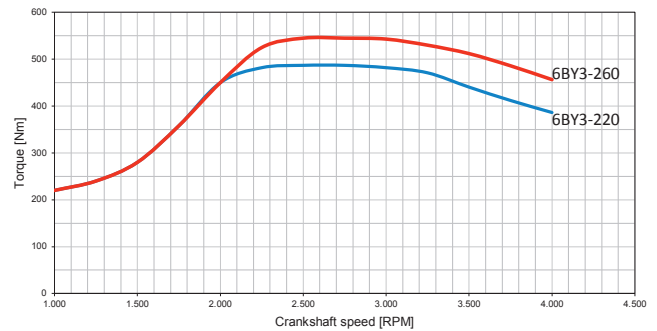
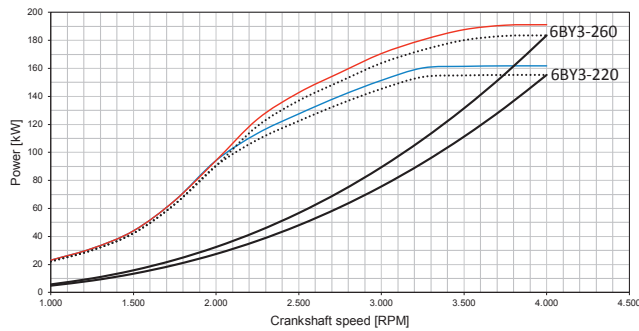

DRIVE SYSTEMS

Model	KMH50A [down angle 8°]		
Type	Hydraulic Actuated Multi-friction disc clutch		
Dry weight	43 kg excl. foot and cooler [=15.5 kg]		
Reduction ratio [fwd/asn]	1.67/1.67	2.13/2.13	2.43/2.43
Direction of rotation	Clockwise & Counterclockwise viewed from the stern		
Lub oil specifications	API class: CF or higher SAE grade #30		
Dry weight - engine & gear	375 kg		

Model	KMH50V [Integral V-drive 12°]			
Type	Hydraulic Actuated Multi-friction disc clutch			
Dry weight	59 kg excl. foot and cooler [=20 kg]			
Reduction ratio [fwd/asn]	1.22/1.22	1.58/1.58	2.08/2.08	2.47/2.47
Direction of rotation	Clockwise & Counterclockwise viewed from the stern			
Lub oil specifications	API class: CF or higher SAE grade #30			
Dry weight - engine & gear	395 kg			

CONTROL SYSTEM "CLASSIC"

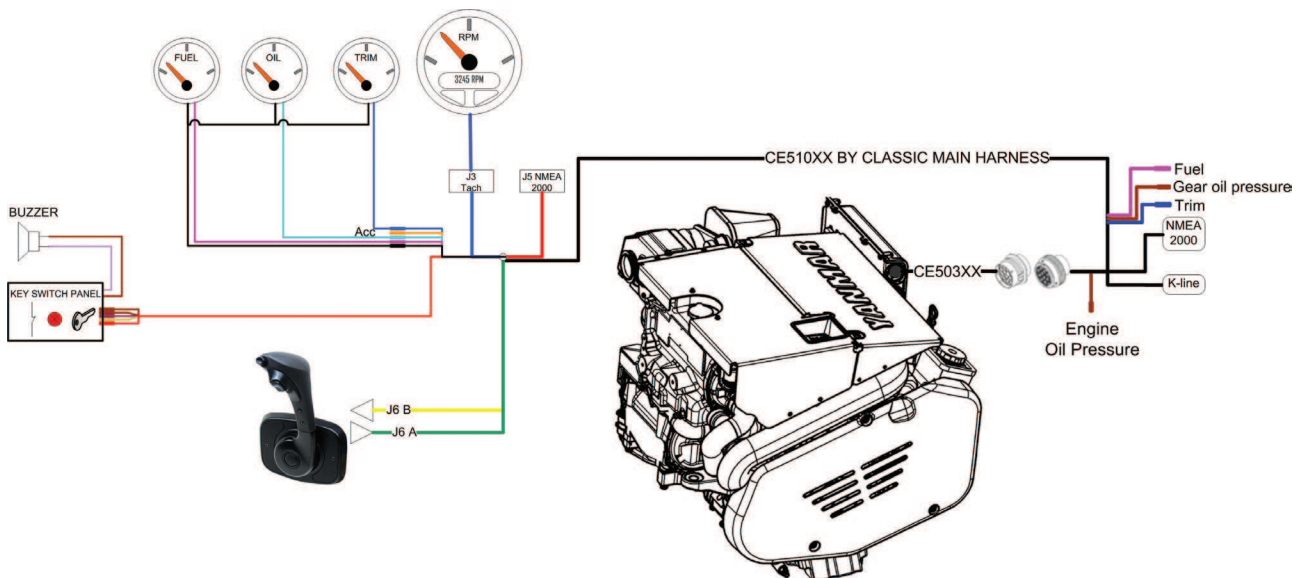

ENGINE ACCESORIES

Standard engine package

- Single pole, 150A Alternator
- Exhaust mixing elbow [L-type]
- Automatic glow-plug controller
- Flexible engine mounting
- Analogue throttle with redundancy function

Optional accessories

- High-riser mixing elbow [instead of L-elbow]
- Exhaust-side 2nd dipstick
- Electric gearshift
- Trolling on gearbox [mechanical and electrical]
- NMEA2000 digital display
- Full NMEA2000 electronic control system [CAN-bus]

NOTE: All data subject to change without notice. Text and illustrations are not binding.