

4JH45 Common Rail Series

Configuration	4-stroke, vertical, water-cooled diesel engine		
Maximum output at crankshaft	* 33.1 kW@3000 rpm	[45 mhp@3000 rpm]	
Displacement	2.19 ltr	[134 cu in]	
Bore x stroke	88 mm x 90 mm	[3.46 in x 3.54 in]	
Cylinders	4 in line		
Combustion system	Direct injection with common rail system		
Aspiration	Natural aspiration		
Starting system	Electric starting 12V - 1.4 kW		
Alternator	12V - 120A		
Cooling system	Fresh water cooling by centrifugal water pump and rubber impeller sea water pump		
Lubrication system	Enclosed, forced lubricating system		
Direction of rotation [crankshaft]	Counterclockwise viewed from flywheel side		
Dry weight without gear	214 kg	[471 lbs]	
Environmental	EU: RCD	BSO II	EMC
	US: EPA Tier 3		
Engine mounting	Rubber type flexible mounting		

NOTE:

Fuel condition: Density at 15°C = 0.84 g/cm³: 1 kW = 1.3596 mhp = 1.3410 HP

* Fuel temperature 40°C at the inlet of the fuel injection pump [ISO 8665: 2006]

Technical data is according to ISO 8665: 2006

DIMENSIONS

Rear view

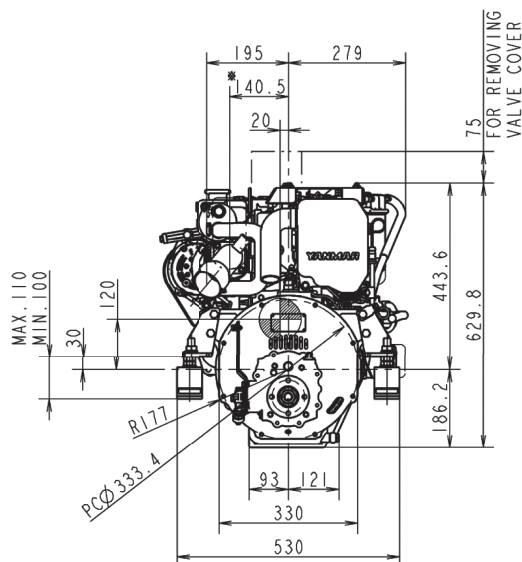

Right side view

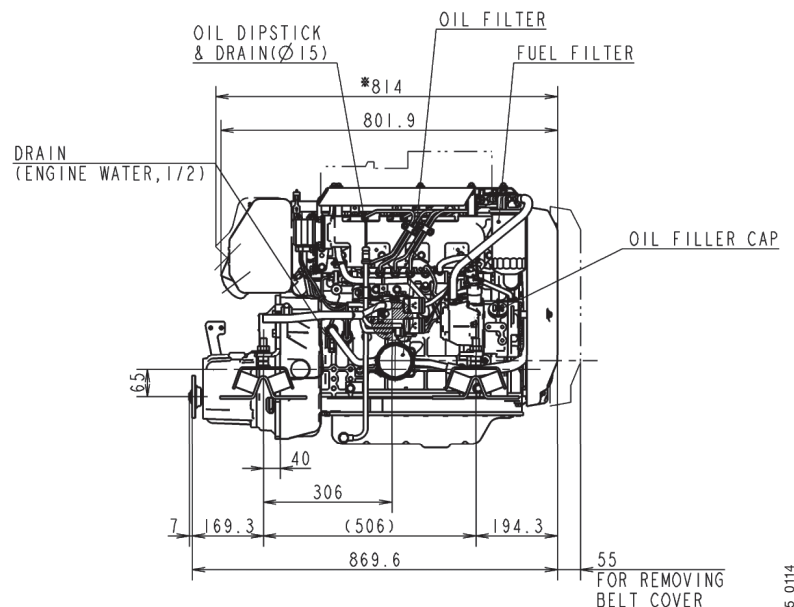

4JH45 with KM35P marine gear

PERFORMANCE CURVES

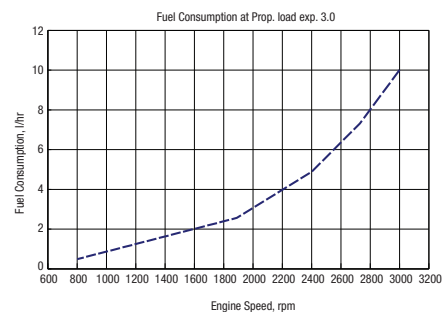
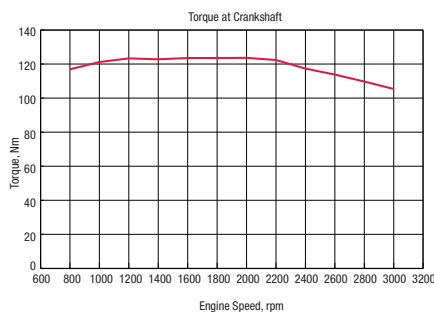
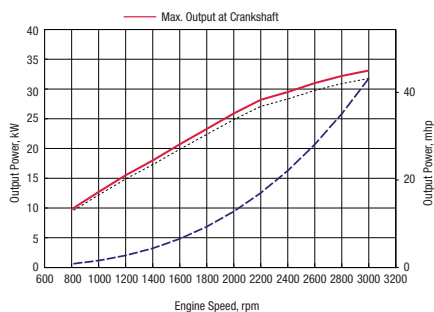

MARINE GEARS/DRIVE

Model	KM35P		KM35A2 [down angle: 7°]		KM4A1 [down angle: 7°]			ZF30M		Saildrive SD60				
Type	Mechanical cone clutch		Mechanical cone clutch		Mechanical cone clutch			Mechanical multi-disc		Mechanical wet type multi-disc				
Dry Weight	12 kg [27 lbs]		13 kg [29 lbs]		29 kg [64 lbs]			28 kg [61 lbs]		44 kg [97 lbs]				
Reduction Ratio [fwd/asn]	2.36/3.16		2.61/3.16		2.33/3.06		2.64/3.06	1.47/1.47	2.14 / 2.14	2.63/2.63	2.15/2.64	2.70/2.64	2.23/2.23	2.49/2.49
Propeller speed [fwd/asn]	1271/949		1149/949		1288/980		1136/980	2041/2041	1402/1402	1141/1141	1395/1136	1111/1136	1345/1345	1205/1205
Direction of rotation [propeller shaft - fwd]	Clockwise viewed from stern		Clockwise viewed from stern		Clockwise & counterclockwise viewed from stern			Clockwise viewed from stern		Clockwise & counterclockwise viewed from stern				
Dry weight - engine & gear	228 kg [503 lbs]		229 kg [505 lbs]		247 kg [545 lbs]			237 kg [522 lbs]		258 kg [569 lbs]				
Length engine and gear/drive	870 mm [34 in]		868 mm [34 in]		926 mm [36 in]			950 mm [37 in]		1113 mm [44 in]				

INSTRUMENT PANELS

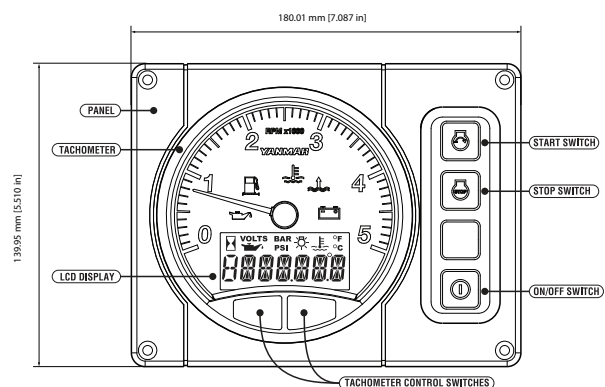

B25 STANDARD

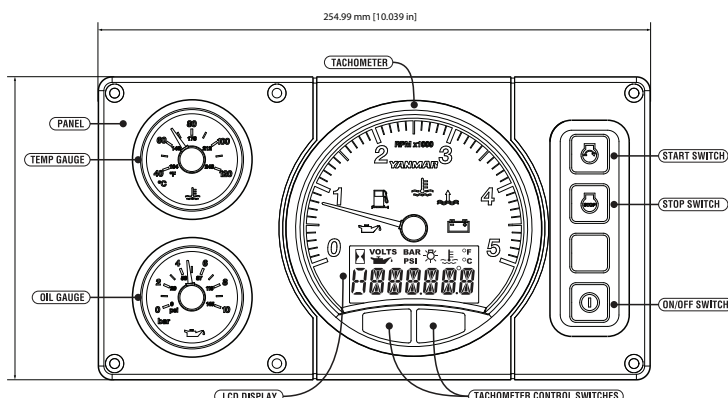

C35 OPTIONAL

ACCESSORIES

Standard Package

- Set of flexible engine mounts
- Exhaust mixing elbow [L-type]
- V-belt safety cover
- Fresh water expansion tank
- Alternator 12V - 120A
- Operation manual
- B25-panel
- Sensor for instrument panel
- Seawaterpump front mounted
- Engine Topcover for protection

Optional

- Second alternator 12V - 130A or 24V - 75A
- High-riser mixing elbow [instead of L-elbow]
- Extension wire harness [4m, 6m, 10m]
- Hot water kit with cocks
- Second station harness
- C35-panel
- Sensor for C35-panel
- Extension saildrive leg [75 mm]
- Propeller cone nut kit SD60
- NMEA 2000 Engine monitory system

NOTE: All data subject to change without notice. Text and illustrations are not binding.